

MITSUBISHI LSTTLs M74LS04P

HEX INVERTERS

DESCRIPTION

The M74LS04P is a semiconductor integrated circuit containing 6 inverter circuits.

FEATURES

- High breakdown input voltage ($V_i \geq 15V$)
- Low power dissipation ($P_D = 12mW$ typical)
- High speed ($t_{pd} = 6ns$ typical)
- Low output impedance
- Wide operating temperature range ($T_a = -20 \sim +75^\circ C$)

APPLICATION

General purpose, for use in industrial and consumer equipment.

FUNCTIONAL DESCRIPTION

The use of Schottky TTL technology enables the achievement of high input voltage, high speed, low power dissipation and high fan-out.

When input A is high, output Y is low, and when A is low, Y is high.

FUNCTION TABLE

A	Y
L	H
H	L

PIN CONFIGURATION (TOP VIEW)

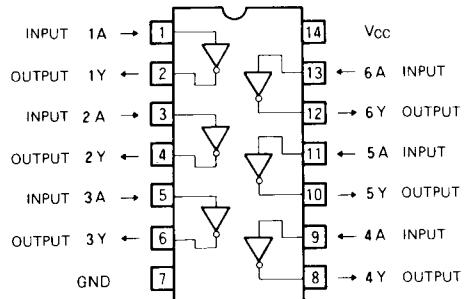

Outline 14P4

CIRCUIT SCHEMATIC (EACH INVERTER)

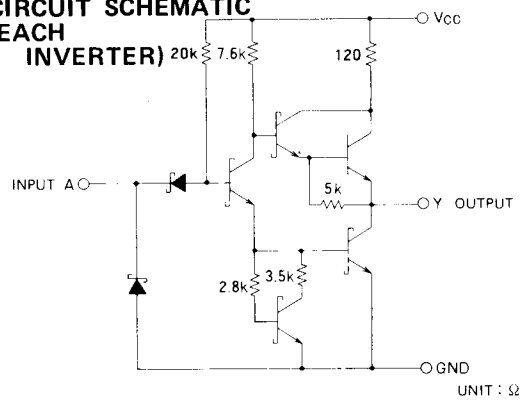

ABSOLUTE MAXIMUM RATINGS ($T_a = -20 \sim +75^\circ C$, unless otherwise noted)

Symbol	Parameter	Conditions	Limits	Unit
V_{CC}	Supply voltage		$-0.5 \sim +7$	V
V_i	Input voltage		$-0.5 \sim +15$	V
V_o	Output voltage	High-level state	$-0.5 \sim V_{CC}$	V
T_{opr}	Operating free-air ambient temperature range		$-20 \sim +75$	$^\circ C$
T_{stg}	Storage temperature range		$-65 \sim +150$	$^\circ C$

HEX INVERTERS

RECOMMENDED OPERATING CONDITIONS (Ta = -20 ~ +75°C, unless otherwise noted)

Symbol	Parameter		Limits			Unit
			Min	Typ	Max	
V _{CC}	Supply voltage		4.75	5	5.25	V
I _{OH}	High-level output current	V _{OH} ≥ 2.7V	0		-400	μA
I _{OL}	Low-level output current	V _{OL} ≤ 0.4V	0		4	mA
		V _{OL} ≤ 0.5V	0		8	mA

ELECTRICAL CHARACTERISTICS (Ta = -20 ~ +75°C, unless otherwise noted)

Symbol	Parameter	Test conditions	Limits			Unit
			Min	Typ*	Max	
V _{IH}	High-level input voltage		2			V
V _{IL}	Low-level input voltage				0.8	V
V _{IC}	Input clamp voltage	V _{CC} = 4.75V, I _{IC} = -18mA			-1.5	V
V _{OH}	High-level output voltage	V _{CC} = 4.75V, V _I = 0.8V, I _{OH} = -400μA	2.7	3.4		V
V _{OL}	Low-level output voltage	V _{CC} = 4.75V, I _{OL} = 4mA		0.25	0.4	V
		V _I = 2V, I _{OL} = 8mA		0.35	0.5	V
I _{IH}	High-level input current	V _{CC} = 5.25V, V _I = 2.7V			20	μA
		V _{CC} = 5.25V, V _I = 10V			0.1	mA
I _{IL}	Low-level input current	V _{CC} = 5.25V, V _I = 0.4V			-0.4	mA
I _{OS}	Short-circuit output current (Note 1)	V _{CC} = 5.25V, V _O = 0V	-20		-100	mA
I _{OCH}	Supply current, all outputs high	V _{CC} = 5.25V, V _I = 0V		1.2	2.4	mA
I _{OCL}	Supply current, all outputs low	V _{CC} = 5.25V, V _I = 4.5V		3.6	6.6	mA

* : All typical values are at V_{CC} = 5V, Ta = 25°C.

Note 1: All measurements should be done quickly, and not more than one output should be shorted at a time.

SWITCHING CHARACTERISTICS (V_{CC} = 5V, Ta = 25°C, unless otherwise noted)

Symbol	Parameter	Test conditions	Limits			Unit
			Min	Typ	Max	
t _{PLH}	High-to-low-level output propagation time	C _L = 15pF		6	15	ns
t _{PHL}	Low-to-high-level output propagation time	(Note 2)		6	15	ns

Note 2: Measurement circuit

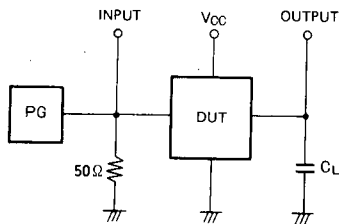

- The pulse generator (PG) has the following characteristics:
PRR = 1MHz, t_r = 6ns, t_f = 6ns, t_w = 500ns,
V_p = 3V_{p.p.}, Z_o = 50Ω
- C_L includes probe and jig capacitance.

TIMING DIAGRAM (Reference level = 1.3V)

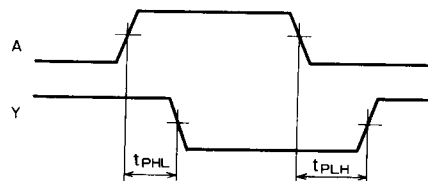

T-90-20

TYPE 14P4 14-PIN MOLDED PLASTIC DIL

Dimension in mm

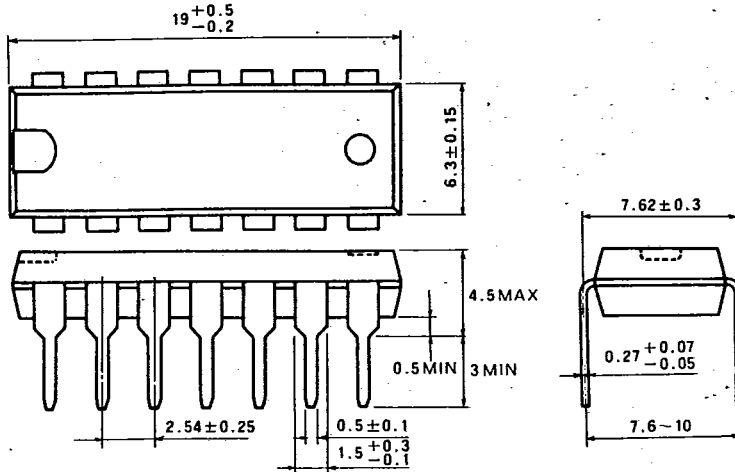

TYPE 16P4 16-PIN MOLDED PLASTIC DIL

Dimension in mm

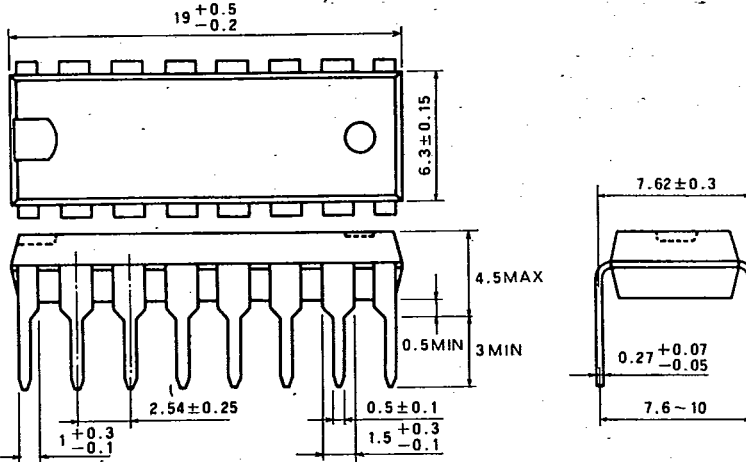

TYPE 20P4 20-PIN MOLDED PLASTIC DIL

Dimension in mm

